



MITSUBISHI ELECTRIC AUTOMATION (THAILAND) CO., LTD.

Bang-Chan Industrial Estate No. 111 Moo 4, Serithai Rd., T.Kannayao, A.Kannayao, BKK 10230 Thailand
 Tel: (66) 2517-1326, (66) 2919-9873 Fax: (66) 2517-1328 URL: www.meath-co.com E-mail: support@meath.co.th

บริษัท มิตซูบิชิ อิเล็กทริก ออโตเมชัน (ประเทศไทย) จำกัด

นิติบุคคลสาขารวมบางชั้น เลขที่ 111 หมู่ 4 ถนนเสรีไทย แขวงคันทนายาว เขตคันทนายาว กทม. 10230

โทรศัพท์: (66) 2517-1326, (66) 2919-9873 โทรสาร: (66) 2517-1328 URL: www.meath-co.com E-mail: support@meath.co.th

MOTOR SPECIFICATION SHEET

MODEL : SC-QR 1/4HP 4P

USED FOR : STANDARD

DESCRIPTION	DETAIL				
PHASE	1				
TYPE	CAPACITOR START				
MODEL NAME	SC-QR				
RATED OUTPUT, HP (kW)	1/4 (0.2)				
POLE	4				
CODE	MEATH CODE : 1M001C-400020QRER1				
OUTLINE DRAWING NO.	ONM74O005-*				
RATED VOLTAGE (V)	220	230	220		
RATED FREQUENCY (Hz)	50	50	60		
RATED CURRENT (A)	2.6	2.7	2.3		
RATED SPEED (min ⁻¹)	1450	1450	1740		
RATED EFFICIENCY (%)	65.5	62.5	70.8		
THERMAL CLASS	120(E)				
RATING	S1 (CONTINUOUS)				
ENCLOSURE CONSTRUCTION	OPEN-PROTECTED				
DEGREES OF PROTECTION	IP20				
METHOD OF COOLING	IC01				
FRAME NO.	A71				
WEIGHT (kg)	6.8				
STANDARD	JEC-2137-2000				
EFFICIENCY RULE	IEC 60034-30-1				
INSTALLATION	FOOT MOUNTED				
ROTATION	CCW (VIEWED FROM SHAFT END)				
BEARING	LOAD SIDE : 6202ZZ				
	OPPOSITE SIDE : 6201ZZ				
BEARING GREASE	UREA GREASE				
VIBRATION	V20				
CIRCUMSTANCE CONDITION	AMBIENT TEMPERATURE : -20 ~ +40°C				
	AMBIENT HUMIDITY : 85%RH OR LESS				
	ABOVE SEA LEVEL : 1000m OR LESS				
	ENVIRONMENT : NO BURSTING/EROSIVE GAS OR VAPOR				
COLOR	MUNSELL N1.5 (BLACK)				
TERMINAL BOX	NO. OF LEAD WIRES : 2				
	SOURCE CONNECTION : TERMINAL BLOCK				
INSULATION RESISTANCE	BY DC 500V MEGGER - ≥100MΩ				
DIELECTRIC TEST	AC 50Hz 1500V - 1min. (Based on rated voltage 220V)				
SHAFT SWING	≤0.03mm				
MATERIAL	FRAME : STEEL PLATE				
	BRACKET : STEEL PLATE				
	SHAFT : CARBON STEEL				
	STATOR CORE : ELECTRICAL STEEL				
	WIRE : ENAMELLED COPPER MAGNET WIRE				
	INSULATOR : POLYESTER FILM				
	VARNISH : EPOXY DENATURALIZATION POLYESTER				
	ROTOR CORE : ELECTRICAL STEEL				
	CONDUCTOR : ALUMINIUM				
	TERMINAL BOX : PLASTIC				
	PAINTING : ALKYD-NITROCELLULOSE RESIN				
PRODUCTION COUNTRY	THAILAND				

CONFIDENTIAL

SPECIFICATION SHEET NO.	ORIGINATOR	CHECKED	APPROVED	DATE
SS-M-7300-A	S.HADSADA	D.CHOEDPONG	T.OGAKE	15/MAR/19

MODEL SC-QR SINGLE PHASE INDUCTION MOTOR OUTLINE DRAWING

CAPACITOR START TYPE
DEGREE OF PROTECTION IP20

STARTING CAPACITOR	35 μ F 250 V
RUNNING CAPACITOR	-

CUSTOMER	_____
USER	_____
FOR	_____
CUSTOMER'S ORDER NO.	_____
QUANTITY	_____
MFG. ORDER NO.	_____

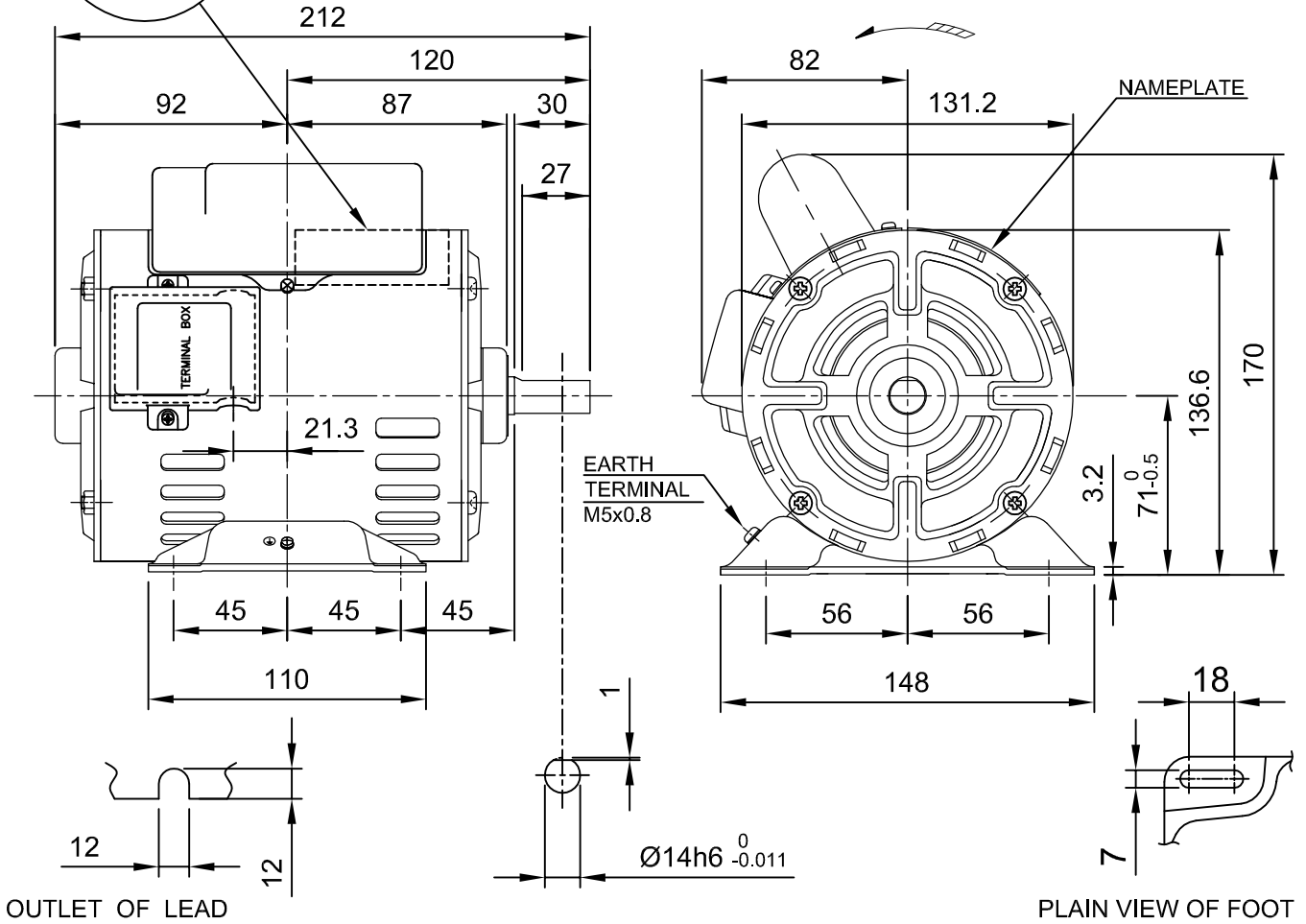

FRAME SIZE	RATING	TH. CLASS	AMB. TEMP.	BEARINGS		COLOR	DIRECTION OF ROTATION	NO. OF LEAD WIRES
				LOAD SIDE	OPP. SIDE			
A71	S1	120(E)	40°C	6202ZZ	6201ZZ	BLACK (MUNSELL N1.5)	CCW	TERMINAL BOARD

OUTPUT		POLE	Hz	VOLT	AMP	RPM	IE CODE - RATED EFF.	REMARK
HP	KW							
1/4	0.2	4	50	220/230	2.6/2.7	1450/1450	IE1- 65.5% / IE1- 62.5%	
			60	220	2.3	1740	IE1- 70.8%	

CONFIDENTIAL

MITSUBISHI ELECTRIC AUTOMATION (THAILAND) CO.,LTD.

	DRAW : S.RITTHA	DATE : 26/Jun/17	REV.
	CHECKED : T.WEERASAK	OUTLINE DRAWING NO.	
DIMENSION IN mm.	DESIGNED : S.RITTHA	ONM740005	
SCALE : NTS.	APPROVED : T.OGAKE		